

Class 125 Iron Y-Strainer

Bolted Bonnet • Blow-Off Plug • Flanged End • 20 Mesh Stainless Steel Screen or Stainless Steel Perforated Screen

- 2" - 12": 125 PSI/8.6 bar saturated steam to 353°F/178°C**
200 PSI/13.8 bar non-shock cold working pressure
- 14" & 16": 100 PSI/6.9 bar saturated steam to 353°F/178°C**
150 PSI/ 10.3 bar non-shock cold working pressure

CONFORMS TO ANSI B16.1 (FLANGE)

MATERIAL LIST

PART	SPECIFICATION
1. Body	Cast Iron ASTM A126 Class B
2. Bonnet	Cast Iron ASTM A126 Class B
3. Screen	Stainless Steel AISI 304
4. Bolt	Carbon Steel ASTM A307
5. Gasket	Metal-Filled Graphite
6. Plug	Cast Iron ASTM A126 Class B



F-721-A
Flanged

DIMENSIONS—WEIGHTS

SIZE	Dimensions										Weight		
	A		B		C		D		E		Lbs.	Kg.	
In. mm.	In. mm.	In. mm.	In. mm.	In. mm.	In. mm.	In. mm.	In. mm.	In. mm.	In. mm.	In. mm.			
2	50	7.87	199.9	5.25	133.4	½	15	6.0	152.4	2.00	50.8	18.00	8.16
2½	65	10.00	254.0	6.50	165.1	1	25	7.0	177.8	2.50	63.5	28.00	12.70
3	80	10.12	257.0	7.00	177.8	1	25	7.5	190.5	3.00	76.2	34.00	15.42
4	100	12.12	307.8	8.25	209.6	1½	40	9.0	228.6	4.00	101.6	60.00	27.22
5	125	15.62	396.7	11.25	285.8	2	50	10.0	254.0	5.00	127.0	95.00	43.09
6	150	18.50	469.9	13.50	342.9	2	50	11.0	279.4	6.00	152.4	133.00	60.33
8	200	21.62	549.1	15.50	393.7	2	50	13.5	342.9	8.00	203.2	247.00	112.04
10	250	26.00	660.4	18.50	469.9	2	50	16.0	406.4	10.00	254.0	320.00	145.15
12	300	29.87	758.7	21.75	552.5	2	50	19.0	482.6	12.00	304.8	579.00	262.63
14*	350	33.25	844.6	26.06	662.0	2	50	21.0	533.4	14.00	355.6	772.00	350.17
16*	400	38.75	984.3	30.15	765.8	2	50	23.5	596.9	16.00	406.4	1133.00	513.92

*Sizes 14" and 16" rated to 150 CWP, 100 SWP

NOTES:

- 2" – 12" size strainers are rated 125 psi saturated steam and 200 psi CWP.
- 14" & 16" size strainer are rated 100 psi saturated steam and 150 psi CWP.
- 2" – 4" size strainers have square shaped bonnets.
- 5" – 16" size strainers have round shaped bonnets.
- Strainer drain plugs are installed hand tight only allowing easy removal for installation of a manual drain valve. If manual drain valve is not used, installer must tighten drain plug for proper seal.

WARNING: This product can expose you to chemicals including lead, which is known to the State of California to cause cancer and birth defects or other reproductive harm. For more information go to www.P65Warnings.ca.gov.

FLOW COEFFICIENTS			
SIZE	C _v	SIZE	C _v
2"	42.7	8	974
2½"	83.1	10	1495
3"	117.0	12	1817
4"	177.0	14	2600**
5"	313	16	4000**
6"	453		

**Estimated

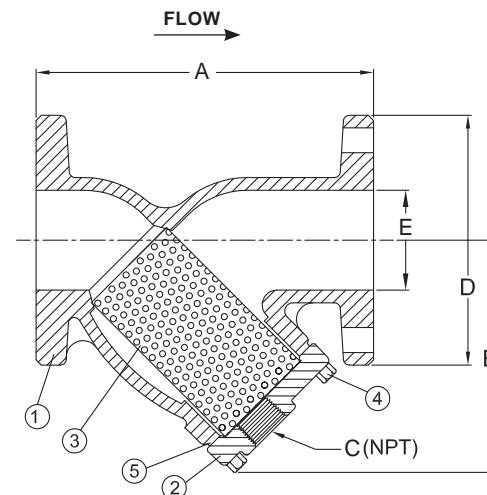

F-721-A
Flanged

SCREEN SIZE:

- 2" - 4": 1/16" perforation (37% open area)**
- 5" - 16": 1/8" perforation (40% open area)**

Visit our website for the most current information.